

WETDUST™

Conditioners for Industrial Dusts

Hydroscrew Ltd
Tel: 0161 777 9290



In terms of function and economy, the WETDUST™ Conditioner is the ideal machine for the evacuation, conditioning and disposal of industrial dust.

Thanks to its particular technical features, the use of innovative materials and extremely short processing time, WETDUST™ is suitable for both continuous and batch operation in heavy-duty applications.

The self-cleaning chamber liner made of nonstick wear-resistant SINT™-material makes daily cleaning, which is necessary with other machines, superfluous. Quick and easy dismantling makes WETDUST™ extremely maintenance-friendly.

Overall Dimensions

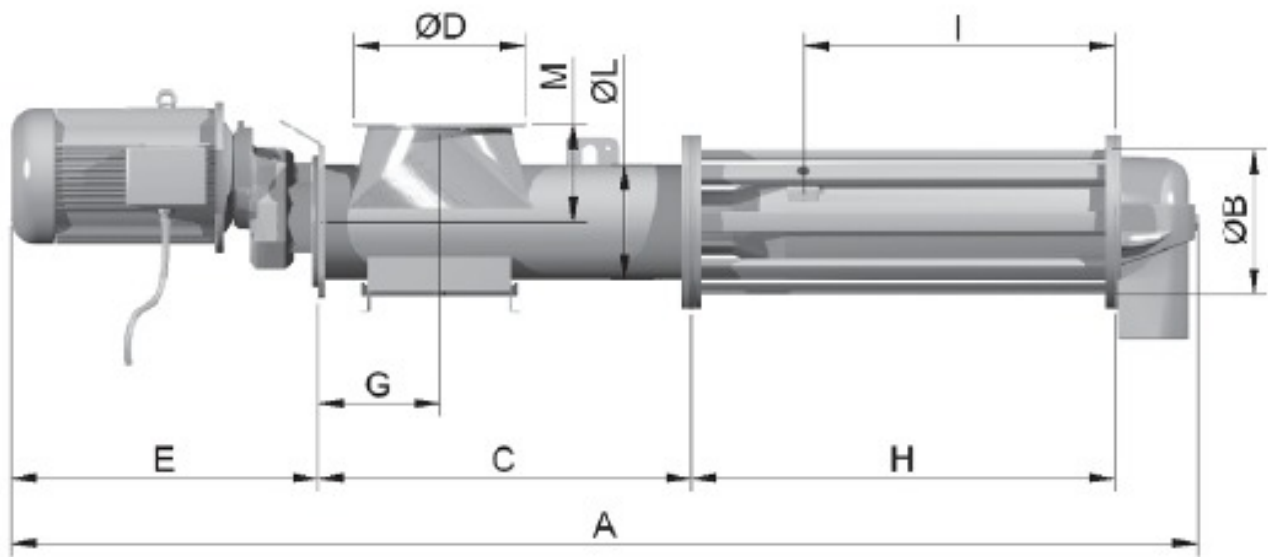

CODE	A	Ø B	C	Ø D	E	G	H	I	Ø L	M	kg	kW	m³/h
WETDUST®	2,115	273	700	273	590	226	650	442	219	186	146	5.5	1.5 - 3

Dimensions in mm



Filtering



Conditioning



Benefits

- ✓ Quick return on investment;
- ✓ Easy to install;
- ✓ Very little maintenance required;

- ✓ No material residue;
- ✓ Rotor completely removable and replaceable.

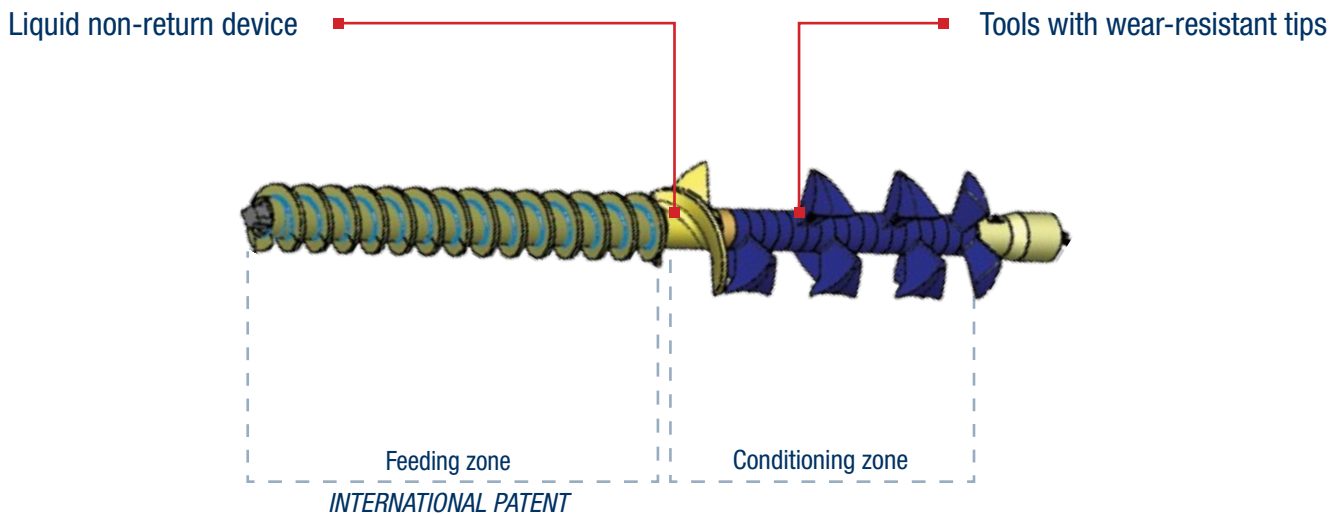
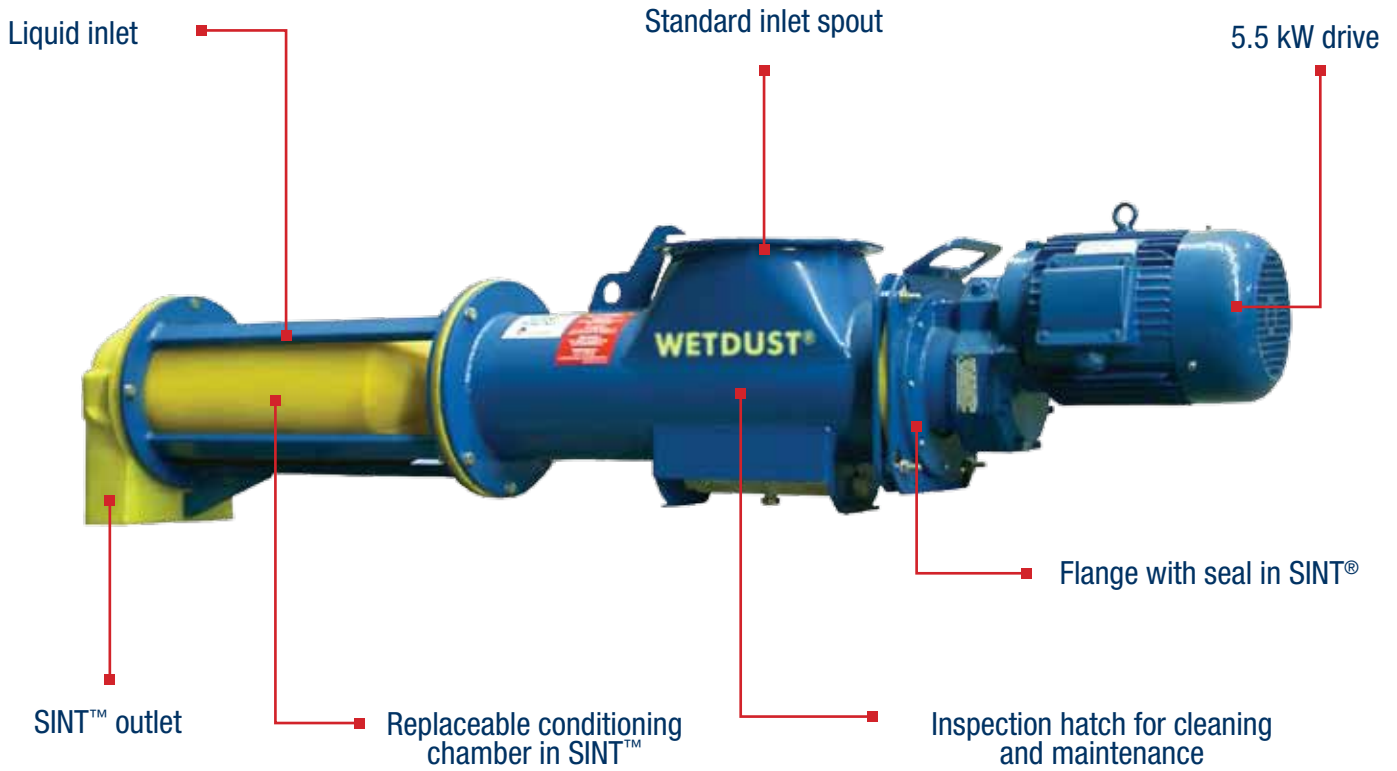

Applications



FOUNDRY



STEEL INDUSTRY



POWER PLANTS



CHEMICAL



December 2010
063001525
Rights reserved to modify technical specifications.



Hydroscrew Ltd (Sales Office)
120 Fir Street, Cadishead
Manchester, M44 5AG, UK
Tel: 0161 777 9290
Fax: 0161 775 2145
Email: info@hydroscrew.co.uk

